

**BALDOR • RELIANCE**

---

# Customer information packet

## ZDPM28150-BV

150HP, 1800, 460V, FL2890, TEBC, F3

## Specifications

Enclosure	TEBC
Frame	FL2890Z
Frame Material	Exposed Laminations
Frequency	60.00 Hz
Output @ Frequency	150.000 HP @ 60 HZ
Phase	3
Synchronous Speed @ Frequency	1800 RPM @ 60 HZ
Voltage @ Frequency	460.0 V @ 60 HZ
Agency Approvals	CCSA US
Auxillary Box	No Auxillary Box
Base Indicator	Rigid
Bearing Grease Type	Polyrex EM (-20F +300F)
Current @ Voltage	168.000 A @ 460.0 V
Duty Rating	CONT
Feedback Device	RESOLVER
Frame Prefix	FL
Heater Indicator	No Heater
High Voltage Full Load Amps	168.0 a
Insulation Class	H
IP Rating	NONE
Motor Standards	NEMA
Mounting Arrangement	F3
Overall Length	46.06 IN
Product Family	General Industrial
Pulley End Bearing Type	Ball
Pulley Face Code	Standard
Service Factor	1.00
Shaft Diameter	2.624 IN
Shaft Ground Indicator	Shaft Grounding
Shaft Rotation	Reversible
Speed	1800 rpm
Starting Method	Full Voltage

## Part detail

Revision	B
Type	AC
Mech. spec.	
Base	
Status	PRD/A
Elec. spec.	PM4057A
Layout	617531-357
Eff. date	03-24-2022
CD Diagram	422927-001
Poles	04
Leads	
Proprietary	False
Created date	11-08-2021

**Thermal Device - Bearing**

None

**Thermal Device - Winding**

Normally Closed Thermostat

---

**Nameplate**

000613006MY

	DUTY	HP	RPM	AMPS	VOLTS	HZ	
	CONT	150	1800	168	460		60
	CONT	150	3000	168	460		100
<b>CAT.NO.</b>	ZDPM28150-BV		<b>SPEC. NO.</b>		F28-A000-0378		
<b>SER.NO</b>		<b>FR</b>	FL2890Z	<b>INSUL</b>	H		
<b>PH.</b>	3	<b>MAX SAFE SPEED</b>		5000	<b>AMB.</b>	40	<b>MIN. AMB.</b> -25
<b>DESIGN NO.</b>	PM4057A	<b>TYPE</b>			<b>ENCL.</b>	TEAO-BC	
<b>S.F.</b>	1.00		<b>D.E. BRG.</b>		75BC02J30X		
<b>ENCL MOD</b>		<b>O.D.E. BRG.</b>		55BC02J30X			
	IP44						

---

000692000VY

---

**MEAS OPEN CIRCUIT VOLTAGE**

---

IS  VOLTS AT  RPM.

---





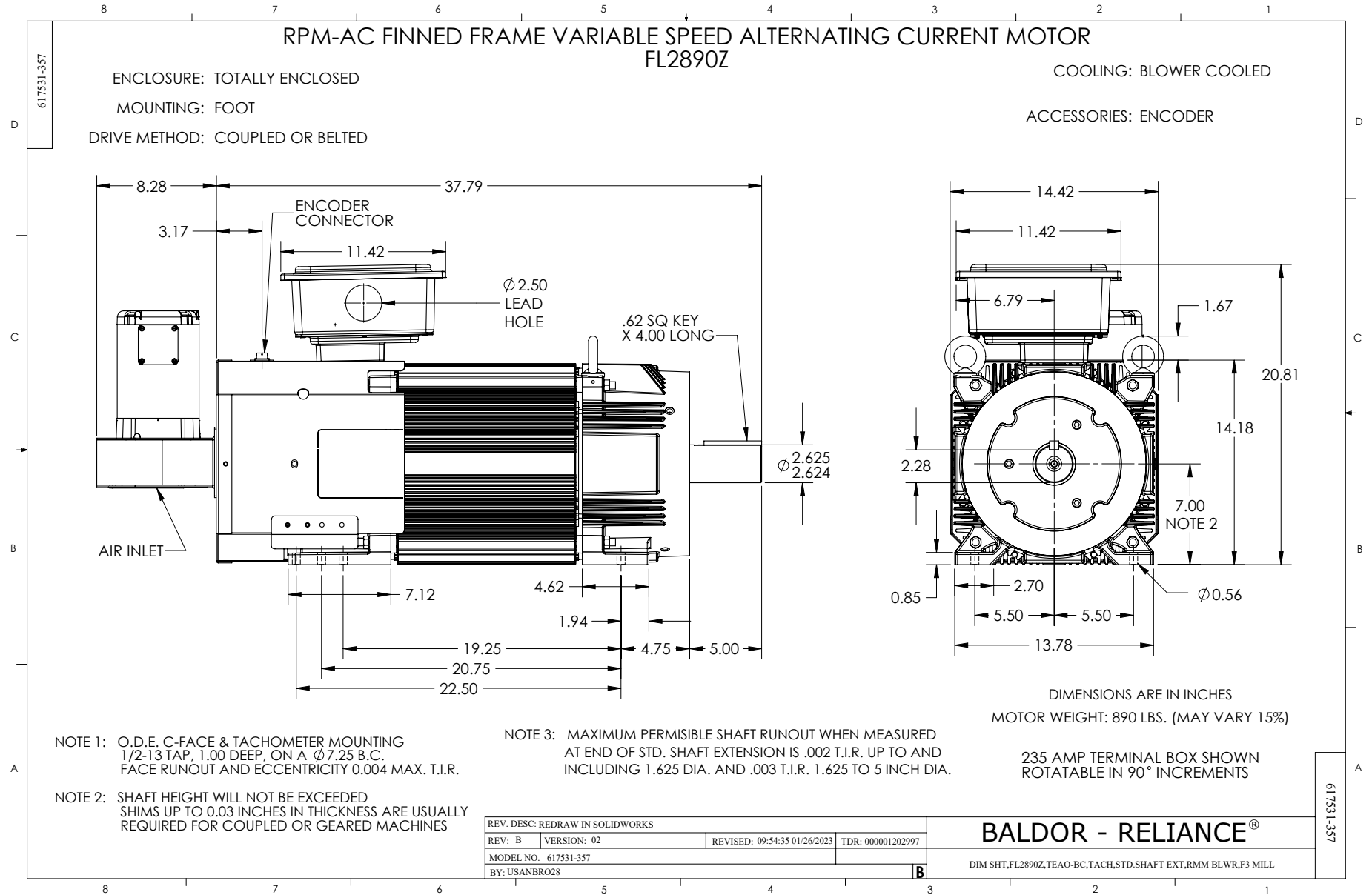



INDUSTRIAL ALTERNATING CURRENT MOTORS  
RPM AC

STEEL, CAST IRON, MILL AND TERMINAL BOARD CONDUIT BOX DIMENSIONS  
NEMA FRAMES RL210 thru RL280 and IEC FRAMES RDL132 thru RDL180  
NEMA FRAMES FL180 thru FL280 and IEC FRAMES FDL112 thru FDL180

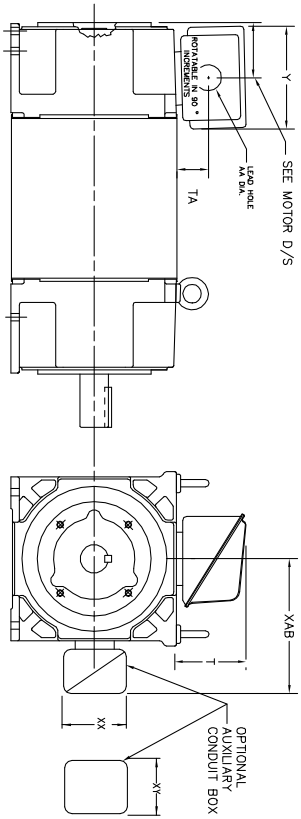

FRAME	TYPE	TERMINAL STRIP	AMPS	C/BOX	Y	TA	T	AA
FL180	STEEL	N	40	706320003A	5.00	1.62	3.00	1.12
FL180	STEEL	N	75	706320003A	6.12	2.38	4.38	1.75/2.00
FL180	CAST IRON	N	208	706320007A	6.82	2.00	7.00	2.50/3.00
FL180 & FDL11	CAST IRON	Y/N	40	706320004B	5.75	2.38	4.38	1.50/1.75
FL180 & FDL11	MILL	Y	100	706310028A	7.75	2.30	4.40	PC29/PG16
FL210 & RL210	STEEL	N	61	0754520009	6.34	2.00	4.12	1.75
FL210 & RL210	STEEL	N	121	0754520010	7.69	2.38	5.25	1.94
FL210 & RL210	STEEL	N	336	706320016A	9.00	4.12	8.42	4.89
FL210 & RL210	CAST IRON	N	110	075460052B	7.25	2.50	5.25	1.5 TAP
FL210 & RL210	MILL	Y	100	706310225A	7.75	2.30	4.40	PC29/PG16
FL210 & RL210	MILL	Y	160	706310056A	9.00	3.06	5.40	PC36/PG16
FL210 & RL210	MILL	Y/N	235	706310637A	11.42	4.00	6.72	2.50
FL250 & RL250	STEEL	N	61	0754520008	6.34	2.00	4.12	1.75
FL250 & RL250	STEEL	N	121	0754520009	7.69	2.38	5.25	1.94
FL250 & RL250	CAST IRON	N	110	075460052B	7.25	2.50	5.25	1.5 TAP
FL250 & RL250	CAST IRON	N	210	706320017A	10.50	4.88	9.00	4.0 TAP
FL250 & RL250	MILL	Y	100	706310225A	7.75	2.30	4.40	PC29/PG16
FL250 & RL250	MILL	Y	160	706310056B	9.00	3.06	5.40	PC36/PG16
FL250 & RL250	MILL	Y/N	235	706310637A	11.42	4.00	6.72	2.50
FL250 & RL250	MILL	Y	400	706310063B	14.39	7.43	12.15	BLANK
FL280 & RL280	STEEL	N	160	706320029A	7.25	3.50	7.06	2.50
FL280 & RL280	STEEL	N	300	706320030A	8.60	4.81	8.42	4.89
FL280 & RL280	STEEL	N	500	702656001C	14.62	7.56	12.70	5.00
FL280 & RL280	CAST IRON	N	140	706320012B	9.25	4.81	8.56	3.0 TAP
FL280 & RL280	CAST IRON	N	210	706320015A	10.50	4.88	9.00	4.0 TAP
FL280 & RL280	CAST IRON	N	510	706320014D	15.00	7.56	12.81	5.0 TAP
FL280 & RL280	MILL	Y	100	706310056A	7.75	2.30	4.40	PC29/PG16
FL280 & RL280	MILL	Y	160	706310056B	9.00	3.06	5.40	PC36/PG16
FL280 & RL280	MILL	Y/N	235	706310637A	11.42	4.00	6.72	2.50
FL280 & RL280	MILL	Y	400	706310063B	14.39	7.43	12.15	BLANK

FRAME SIZE	OPTIONAL AUXILIARY CONDUIT BOX DIMENSIONS (MAXIMUM)								
	XAB	XX	XY	PART NUMBER	FRAME SIZE	PART NUMBER			
FL210/FL180/FL280/FL180	7.38	4.25	4.25	602007-26-A	FL210/FL180/FL280/FL180	10.88	8.00	8.00	706310-3-B
FL250/FL180/FL280/FL180	8.44	4.25	4.25	602007-26-A	FL250/FL180/FL280/FL180	11.88	8.00	8.00	706310-3-B
FL280/FL180/FL280/FL180	9.12	4.25	4.25	602007-26-A	FL280/FL180/FL280/FL180	12.62	8.00	8.00	706310-3-B

- (1) 7/8" PIPE TAP
- (2) CUSTOMER TO PROVIDE HOLE PER CONDUIT.
- (3) DIM SA ON 1" DIA DN W/2

TERMINAL BOX CAN BE ROTATED FOR LEAD INLET AT TOP, SIDES OR BOTTOM  
TERMINAL BOX LOCATED ON OPPOSITE SIDE WHEN F-2, V-1, V-4, V-5, V-7,  
OR C-1 MOUNTING IS SPECIFIED. BOX LOCATED ON TOP WHEN SPECIFIED.

CUSTOMER IS RESPONSIBLE FOR DETERMINING THAT BALDOR'S PRODUCT WILL PERFORM SUITABLY IN THE INTENDED APPLICATION.

REV. DESC: ADD 706310-637 & 639 BOX	VERSION: 06	TDR: 000001180260
REV. LTR: F	REVISED: 11: 08: 56 10/26/2021	BY: RCGRWM
FILE: \RGG\00003\692		
MTL: -		

BALDOR - RELIANCE®

DIM SHT NEMA RL210-RL280 FL180-FL280 IEC RDL132-RDL180

422927-001

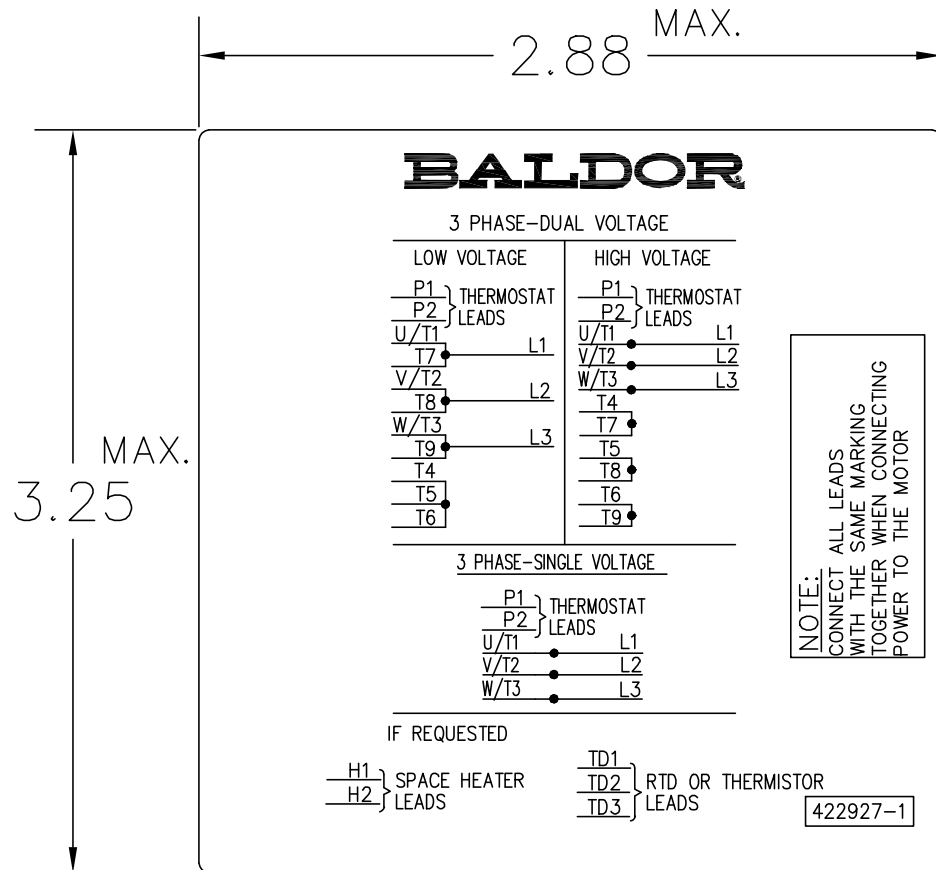

NOTE:  
DATA TO BE SIZED  
SO THAT IT FITS INTO  
MATERIAL DECAL  
DIMENSIONS. MAKE  
LETTERS & NUMBERS  
AS LARGE AS POSSIBLE.

MATERIAL: CERAMATIC DGF-P4  
PERMA GRIP ADHESIVE

ALL LETTERS, NUMBERS  
AND LINES TO BE BLACK  
ON WHITE BACKGROUND.

422927-001

REV. DESC: CHANGE BACKGROUND COLOR FROM GOLD TO WHITE		
REV. LTR: B	VERSION: 02	TDR: 00000788708
FILE: \RGG\00000\203	REVISED: 08:09:29 03/04/2013	
MTL: -	BY: RGGWT	

**BALDOR**

EXTERNAL CONNECTION LABEL

SH 1 of 1